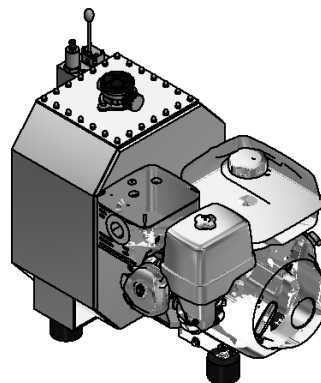
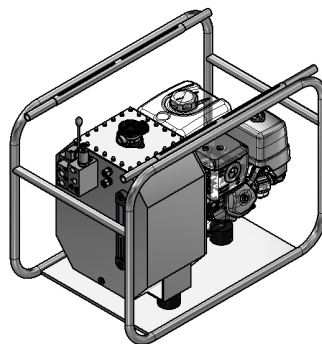

BHPI40-H08-03-001 Serie
Tekniske Data
Bensin hydraulisk aggregat

Motor:	
Motortype	Honda GX340
Kjøling	Luftkjøling
Sylindervolum	88*64mm
Effekt Kw/HK	8Kw
Max Dreiemoment	26.4 Nm @2500Rpm
Utslippskrav	EPA EMISSION REGULATION, Tier 3
Dieseltank	6.1 Liter
Støynivå	N/A
Hydraulikk:	
Anbefalt olje	ISO 32
Pumpe	Variabel pumpe
Max trykk	Opp til 350Bar
Max Flow	5.1l/min kont. 7.1l/min
Tank størrelse	40 Liter
HPU	
Dimensjon LxBxH	71cm x 43cm x 60xm
Vekt	62kg uten olje/ramme*

Standard utstyr

- Hydraulikk tank i marinealuminium
- Returfilter 10My
- Pustefilter 3My
- Nivåglass med tempmåler
- Retningsventil

Tilleggsutstyr

- Ramme til HPU 14kg
- EI-Start 12V/24V
- EI-Start 12V/24V
- Dynamo 12V/24V
- Trykkfilter
- auto gasspådrag
- Radiostyring
- Overtrykksventil
- Variabel pumpe
- 70 Liters tank